

[rexresearch.com](http://rexresearch.com)

---

## **ElectroCulture Patents**

---

---

**USP # 3,935,670**

**Apparatus for Selectively Applying Electrical Current to Plants**

**Ricks H. Pluenneke / Willis G. Dykes**  
**February 3, 1976**

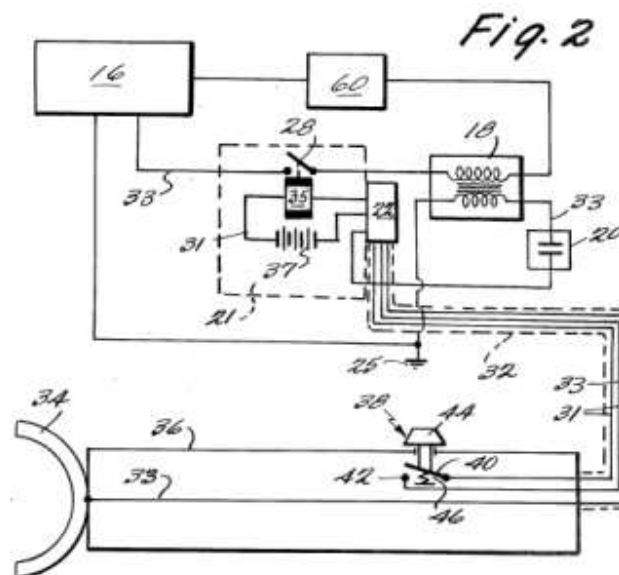
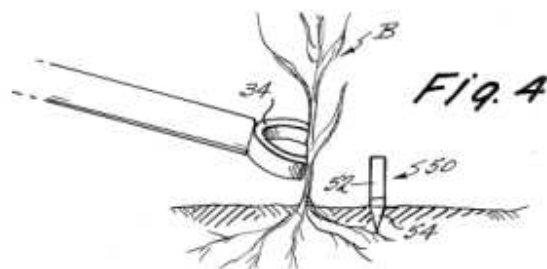
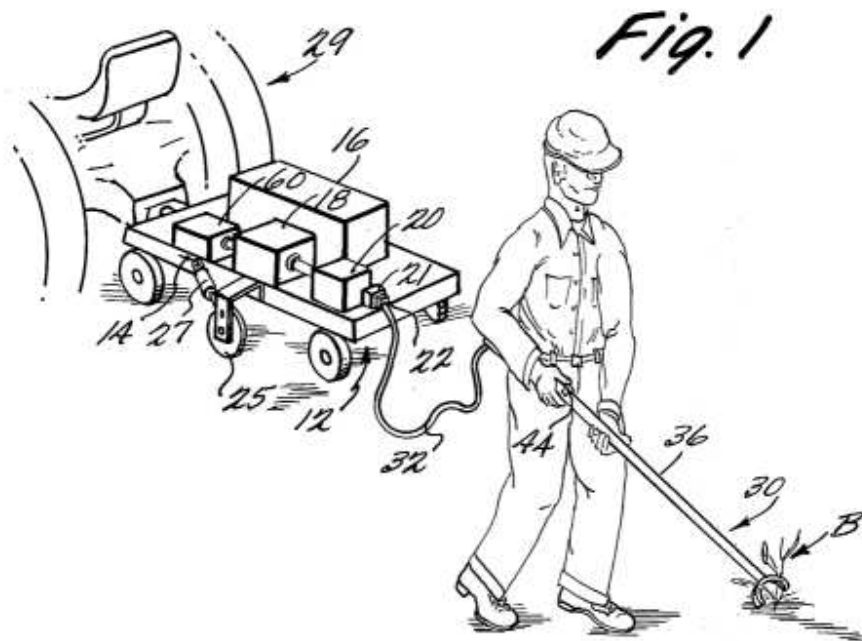

**Abstract** ~ Apparatus for destroying selected plants by the application of electricity thereto. A source of high-voltage electrical current is mounted on a moveable platform, and a grounding wheel or the like is provided for insuring safety of the apparatus by grounding various electrical source components. A conductive tip portion of a non-conductive staff member may be connected to the source of current by a cord, and an operator controlled switch in a secondary control circuit is mounted on the staff member. The switch is normally open so that the conductive tip portion will not be energized should the operator release his grip on the staff member. By actuating the switch and bringing the tip portion into mere touching engagement with a plant stem, plant destruction may be effected.

**USP # 3,940,885**  
**Process and Equipment for Treating Seeds and Product Thereof**

**Oscar S. Gray**  
**March 2, 1976**

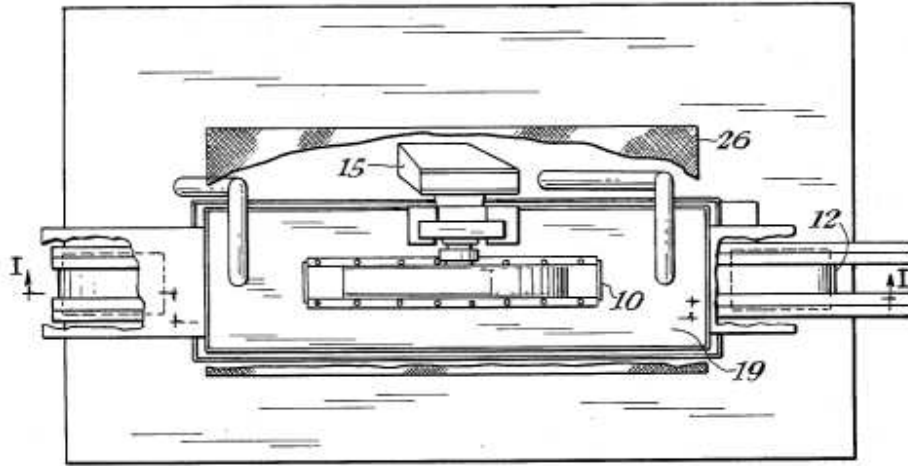

Fig. 2.

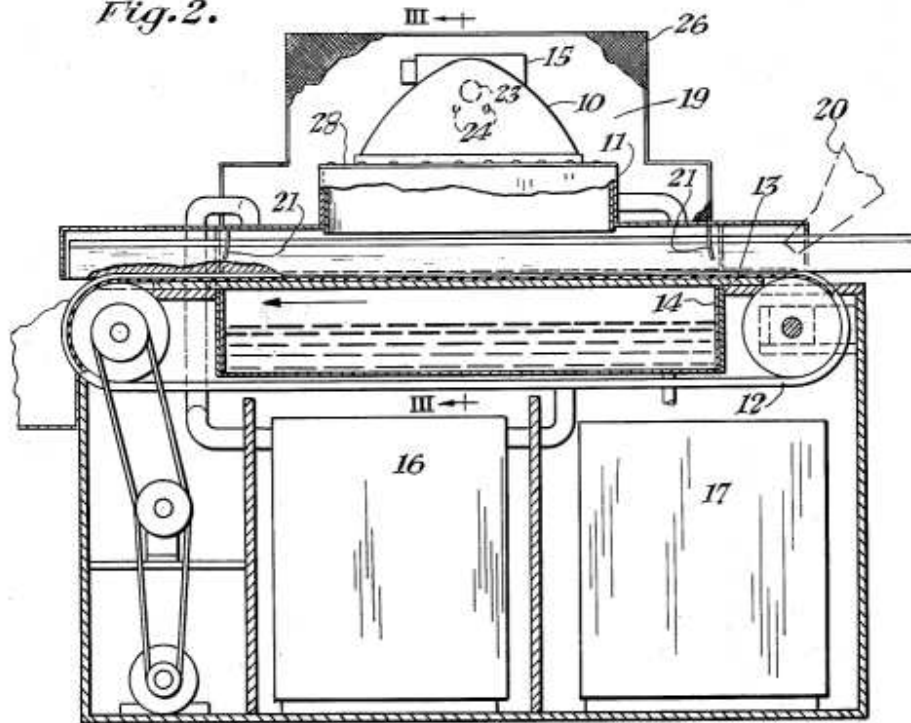
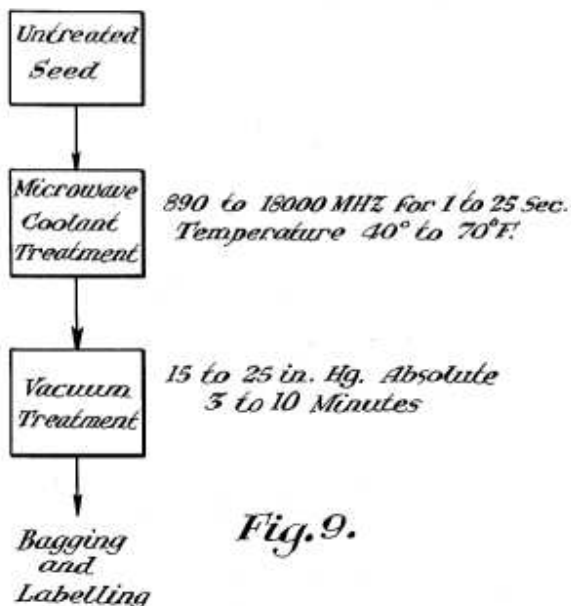

Fig. 1.



**Abstract** ~ Seeds are subjected to microwave energy and a coolant gas, then subjected to a partial vacuum to stimulate growth and stabilize such stimulation. Seeds so treated have superior growth characteristics and are more resistant to disease and weather hazards. Apparatus for effecting this process is also disclosed.

**USP # 4,007,794**  
**Top Desiccation of Crop Plants**

**Ricks H. Pluenneke / Willis G. Dykes**  
**February 15, 1977**

**TABLE A**

Voltage (no load) (kv)	(load)	Speed M.P.H.	Current Amps (under load)	Direction	Energy Density (approx. kw/ft)	Vine Kill Ratings
<b>No treatment (control)</b>						
20	:12.5	0.5	1.14	one	11	1.00
20	:12.5	0.5	1.14	two	11	3.65
20	:12.5	1.0	1.14	one	11	4.05
20	:12.5	1.0	1.14	two	11	3.47
20	:12.5	1.0	1.14	two	11	3.87

**Abstract** ~ The above-ground growth of potatoes and like root crops are contacted with high voltage electricity several days prior to harvesting, the electricity desiccating the above-ground portion of the crops while not harming the tubers. A no-load voltage of about 20 kv with an energy density of about 11-15 kw/foot of width treated is effective. Low-bush blueberries, and like perennial crops, are pruned by contacting the above-ground growth thereof with electricity. Pruning, in the case of blueberries, is most effective when done approximately every other year in the case of blueberries, a no-load voltage of 10-20 kv with an energy density of about 2-3 kw/foot of width treated being effective.

## Description

### BACKGROUND AND SUMMARY OF THE INVENTION

The invention relates to a method of killing mature root crop tops prior to harvesting, and to a method of pruning certain perennial crop plants, with minimum adverse impact on the environment. In the past it has been proposed to kill plants with electricity, as shown in U.S. Pat. Nos. 2,007,383, 2,607,165, 2,632,285, 3,543,488, and 3,559,337. It has not previously been recognized, however, that certain root crops can be contacted with electricity to destroy the above-ground portions thereof while not adversely affecting the tubers -- the crop portion -- thereof. This has been recognized according to the present invention, however, and may be utilized to facilitate the harvesting of potatoes, beets, carrots, onions, and the like. According to the present invention, some time before harvesting, after the crops to be harvested are substantially mature, the above ground growth of the crops is contacted with electricity from a high-voltage source, which causes desiccation thereof; for instance for potatoes, the above ground growth is contacted with electricity from a 20 kv source about 10-20 days prior to harvesting, and by the time for harvesting the skin of the potatoes has become more firm, the potatoes are not subject to disease (i.e. leaf roll), and harvesting thereof with conventional equipment is greatly facilitated.

In the past, it has been known to kill the above-ground growth of some root crops -- i.e. potatoes -- prior to harvesting to facilitate the harvesting and firm the skin thereof, but past methods have had a number of drawbacks. For instance, when conventional chemicals are used to kill the above-ground growth, they can and do leave residues which might migrate to the food portion of the crop, and in any event are retained in the soil to some extent and can be assimilated by the next year's crop; if the chemicals are applied too closely to a time when it rains, they may be washed off before they can be effective for killing the above-ground growth and thus a complete wasteful repeat of the application is necessary; dense foliage is not easily penetrated; also; the chemical treatments are often temperature dependent which means that it is not always possible to apply them at the optimum time, and therefore optimum harvesting conditions may not exist. Roto-beating -- that is, actual physical destruction of the above-ground growth -- also is practiced in addition to or in place of chemical application. While roto-beating avoids some of the problems inherent with chemical treatment, it is fairly energy intensive, and is not as completely successful as is the chemical treatment.

It has also not been previously recognized that certain perennial crops -- such as blueberries -- can be pruned with the application of high-voltage electricity, but not destroyed. Conventional proposals for the application of electricity to plants, such as the patents mentioned above, do not recognize that a crop plant may not be killed but merely the above-ground growth thereof destroyed by the application of electricity. According to the present invention, blueberries and like perennial crops, may be treated by the application of electricity -- from a 20 kv source, for instance -- to the above-ground portions thereof every other year to prune the bushes and thereby encourage future growth. Conventionally, pruning of blueberry bushes on a commercial scale is accomplished by burning off of the plants with oilfired burners. While this effectively prunes the plants without serious damage to the root systems, it also destroys much of the organic material in the soil, and is fairly energy intensive.

Thus according to the present invention, the pruning of perennial crops, such as low-bush blueberries, and the destruction of the above-ground growth of root crops, such as potatoes, carrots, onions, and beets, are greatly facilitated by the application of high-voltage electricity to the above-ground portions of the plants. Apparatus such as shown in our U.S. Pat. No. 3,919,806, the disclosure of which is hereby incorporated by reference herein, may be utilized for practicing the method according to the present invention.

It is the primary object of the present invention to provide improved methods for the pruning of certain perennial crops and for facilitating the harvesting of certain root crops, such methods eliminating many of the drawbacks inherent in prior art methods. This and other objects of the invention will become clear from an inspection of the detailed description of the invention, and from the appended claims.

**DETAILED DESCRIPTION OF THE INVENTION**

According to the present invention, potatoes and other root crops, such as beets, carrots, and onions, are treated by bringing the above-ground portions of the plants into contact with a high-voltage source of electricity. While the exact voltage applied will vary with the soil conditions, type of crop, etc., it has been found that 20 kv (no load) appears to be an ideal voltage for effecting desiccation of the above-ground portions of the crops, while not adversely affecting the root, food portions thereof. An effective energy density of about 11-15 kw/foot width of crop being treated normally results when such a no-load voltage is being used. While 20 kv and an energy density of 11-15 kw/foot have been found to be workable values, the range of each can vary widely and still be effective for accomplishing the desired result. Any voltage and energy density that results in the application of about 250 milliamps or more to the above-ground stems of root crops (i.e. potatoes) is believed effective. A maximum on the voltage and energy density would be that which would apply so much current that the root portion of the crop was adversely affected; however, there appears to be no adverse effect whatsoever when 12 kv with an energy density of about 11-15 kw/ft is utilized.

The following table gives a summary of actual test results for the method of top killing of root crops according to the present invention. Katahdin potato vines in Maine were treated approximately 21 days prior to harvesting, the potatoes being harvested approximately 4 months after planting, and the vine kill rating of the method according to the present invention was determined one day prior to harvest. The kill rating code for the below (and the succeeding) table is 1=no or poor kill of leaves and stems, 2=90% of leaves but poor stem kill, 3=100% of leaves and 40% of stems killed, 4=100% of leaves and 70% of stems killed, and 5=100% of leaves and stems killed. By dragging behind a tractor six 24 inch vertical chains (covering a 16 inch horizontal band) which were electrically energized with AC current, the following results were obtained:

**TABLE A**

Energy Density (no load)	Voltage (kv)	Speed (M.P.H. (under load))	Current (amps)	Vine Kill (load)
1.00	20	12.5	0.5	1.14
11	3.65	20	12.5	0.5
1.14	two	11	4.05	20
1.0	1.14	two	11	3.87

There was slight regrowth on all plots, however, this regrowth may -- it is believed -- be avoided to a large extent by harvesting closer to the date of treatment with the electricity. Treatment with electricity should precede harvesting by 10-20 days.

The values in Table A may be compared with similar values for a variety of chemical treatments of the same type of potatoes grown in the same area in generally the same time span. The results of such chemical treatment are listed below (all applied on days when it did not rain):

**TABLE B**

There was slight regrowth on many plots where the kill was not complete.

It is noted that the effectiveness of the kill with Dow General and Des-I-Cate may be increased through proper application thereof by adjustment of the differential pressure and water dilution (applied with an F.M.C. sprayer) to 5.0 when the differential pressure and water dilution factors are optimized.

It will be seen that treatment with electricity is just as effective as many of the chemical treatments applied above, and additionally has the previously mentioned advantages of no environmental degradation, ready penetration of thick growth, and no adverse effect when it rains or is cold. It is possible to increase the effectiveness of the treatment with electricity by watering down the ground before treatment, or by application of water with ionic materials (i.e. fertilizer salts) therein; this

insures no damage to the tubers by allowing the electricity to dissipate to the ground quickly. Also, it is possible to combine the treatment with electricity with chemical treatment (either before or after electrical treatment), diminishing the amount of chemical that must be applied for successful treatment, and allowing one treatment to be made despite the weather conditions.

According to the method of the present invention, low-bush blueberries have been pruned successfully, substantially all of the above-ground growth thereof being killed by contacting the blueberry bushes (or other perennial crop plants) with 10-20 kv (no load) at ground speeds of approximately 3 miles/hour, 2-3 KW of output power per foot of width being provided. This method may be repeated every other year to increase the yield from the plants, no apparent adverse effect on the roots taking place.

While the invention has been herein shown and described in what are presently conceived to be the most practical and preferred embodiments thereof, it will be obvious to one of ordinary skill in the art that many modifications may be made thereof within the scope of the invention, which scope is to be accorded the broadest interpretation of the appended claims so as to encompass all equivalent process and methods.

---

**USP # 4,020,590**

**Apparatus and Method for Exposing Seeds to a Magnetic Field**

**Albert R. Davis**  
**May 3, 1977**



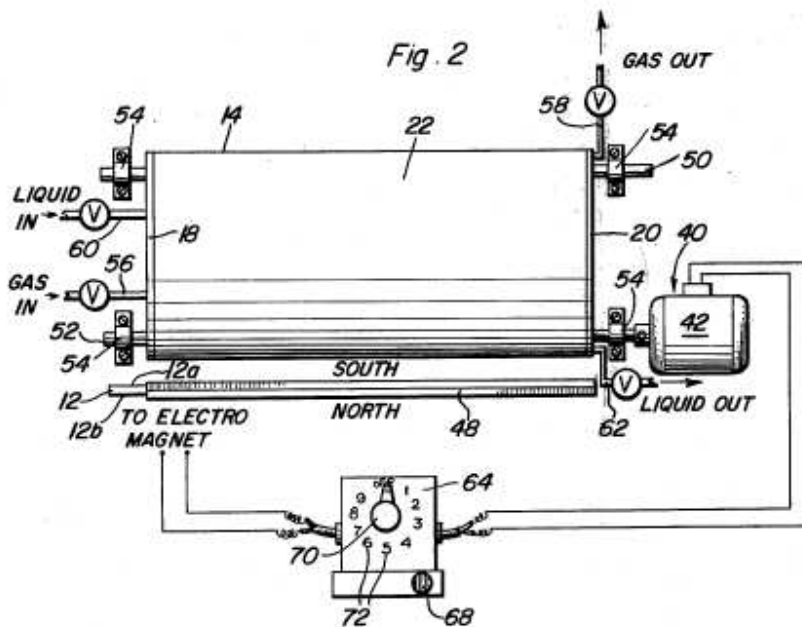
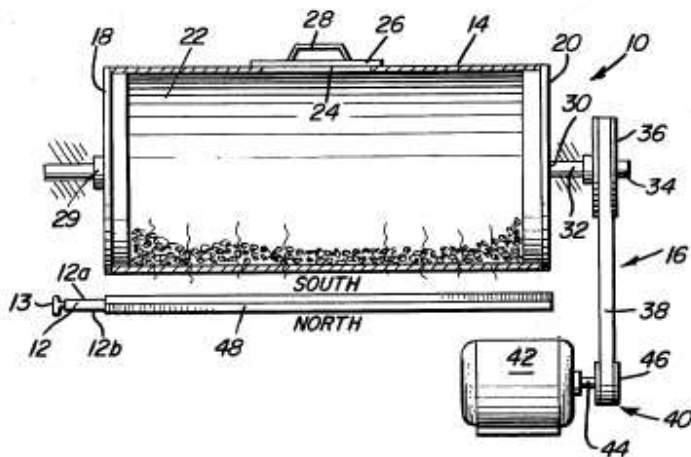

**Abstract** ~ Apparatus for magnetically treating seeds comprises a magnet for producing a unipolar magnetic field, an enclosed generally cylindrical housing having a closable access opening therein in which said seeds are placed for treatment, drive means associated with the housing for rotating said housing and imparting rolling and tumbling motion to the seeds within the housing, the housing being disposed with respect to the magnet such that the seeds move through the magnetic field as they roll and tumble. By magnetically treating the seeds in a unipolar magnetic field while rolling and tumbling the seeds, the characteristics of plants grown therefrom are favorably altered.

**USP # 4,047,326**  
**Vascular Contact Rotating and Stationary Abrading Electrode Devices for Electric Weed Killing**

**Robert C. Tibbs**  
**September 13, 1977**

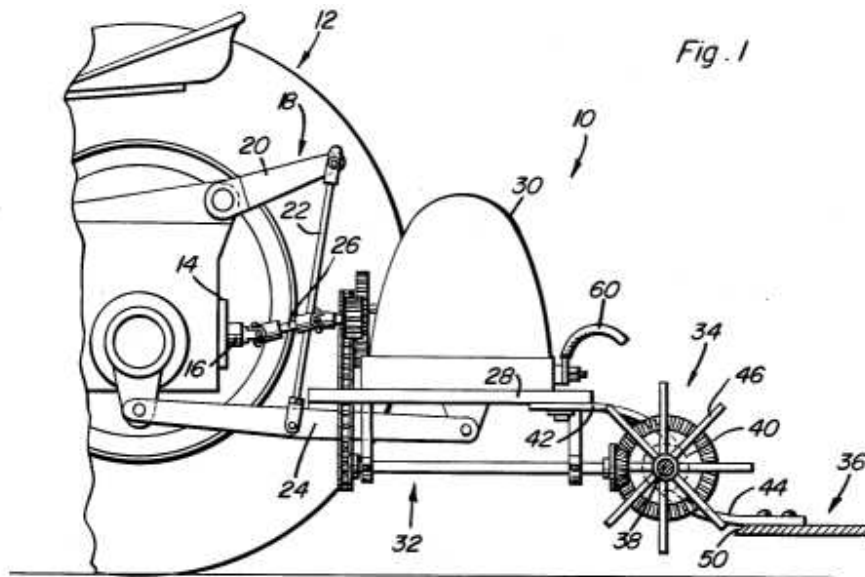

**Abstract** ~ Undesirable vegetation or weeds are destroyed by electrical current conducted therethrough by prolonged contact with electrodes. Internal plant tissues of the vegetation are exposed for electrode contact by removal of electrically resistant external layer portions through abrasion of the plant stems or stalks along a path of movement of the apparatus to reduce the electrical energy requirements for plant destroying purposes.

**USP # 4,092,800  
Vegetation Control**

**James R. Wayland, Jr., et al.  
June 6, 1978**

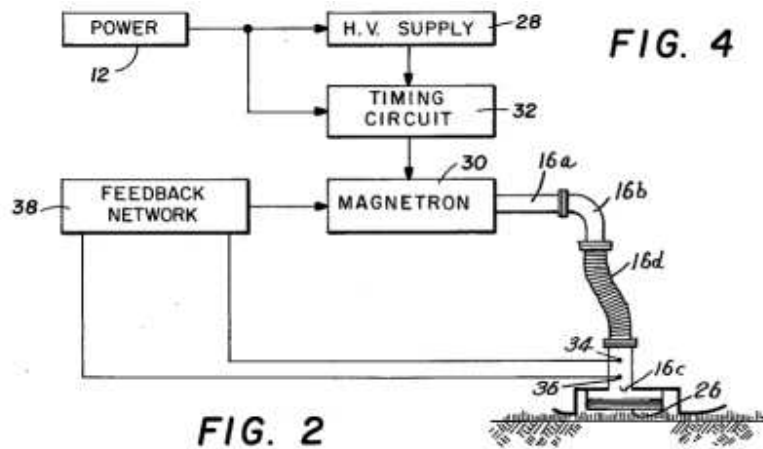

**Abstract** ~ Microwave transmitters generate electromagnetic energy at a desired frequency in the range of from 300 MHz to 300 GHz. Energy derived from the microwave transmitters is coupled into a waveguide for transmission to an energy radiator coupled to the waveguide. The energy radiator, waveguide and microwave transmitters are vehicle mounted such that the radiator is made to pass over areas in which it is desired to control vegetation. Vegetation, including seeds, in the path of energy emitting from the radiator absorbs the energy from the field resulting in internal changes in the plant or seed causing death or debilitation of the vegetation or seed.

**USP # 4,094,095****Method and Apparatus for Using Electrical Current to Destroy Weeds...**

**Willis Dykes**  
**June 13, 1978**

**Abstract** ~ A method and apparatus for destroying weeds growing in and around crop rows without destruction of crops growing therein. A plurality of electrically conductive spring members are disposed in a generally horizontal plane and connected to a high voltage source of electricity. The spring members have a spring constant such that relatively stiff crops plants will deflect the spring members while relatively flexible weeds will not deflect them. Substantially all of the plants in and around the crop rows are contacted with current-carrying portions of the spring members by moving the spring members relative to the crop rows parallel to the crop rows. A larger dwell time of contact is provided between the spring members and the relatively flexible weeds than the dwell time of contact between the spring members and the relatively stiff crop plant so that the weeds receive sufficient electrical energy to result in destruction thereof, while the crop plants do not receive sufficient electrical energy to result in destruction thereof. The difference in dwell time is provided by forming each spring member so that it has one end connected to a supporting member and the first portion extending from the connected end making a first angle  $\alpha$  with a line along the direction of movement of the spring member, and having a free end with a second portion adjacent the free end making a second angle  $\beta$  with a line along the direction of movement of the spring member, the angle  $\beta$  being substantially greater than the angle  $\alpha$ , and by disposing the connected end of the spring member between crop rows while the free end extends into a crop row during movement of the spring member to affect contacting.

---

**USP # 4,177,603****Plant Destruction Using Electricity**

**Willis Dykes**  
**December 11, 1979**

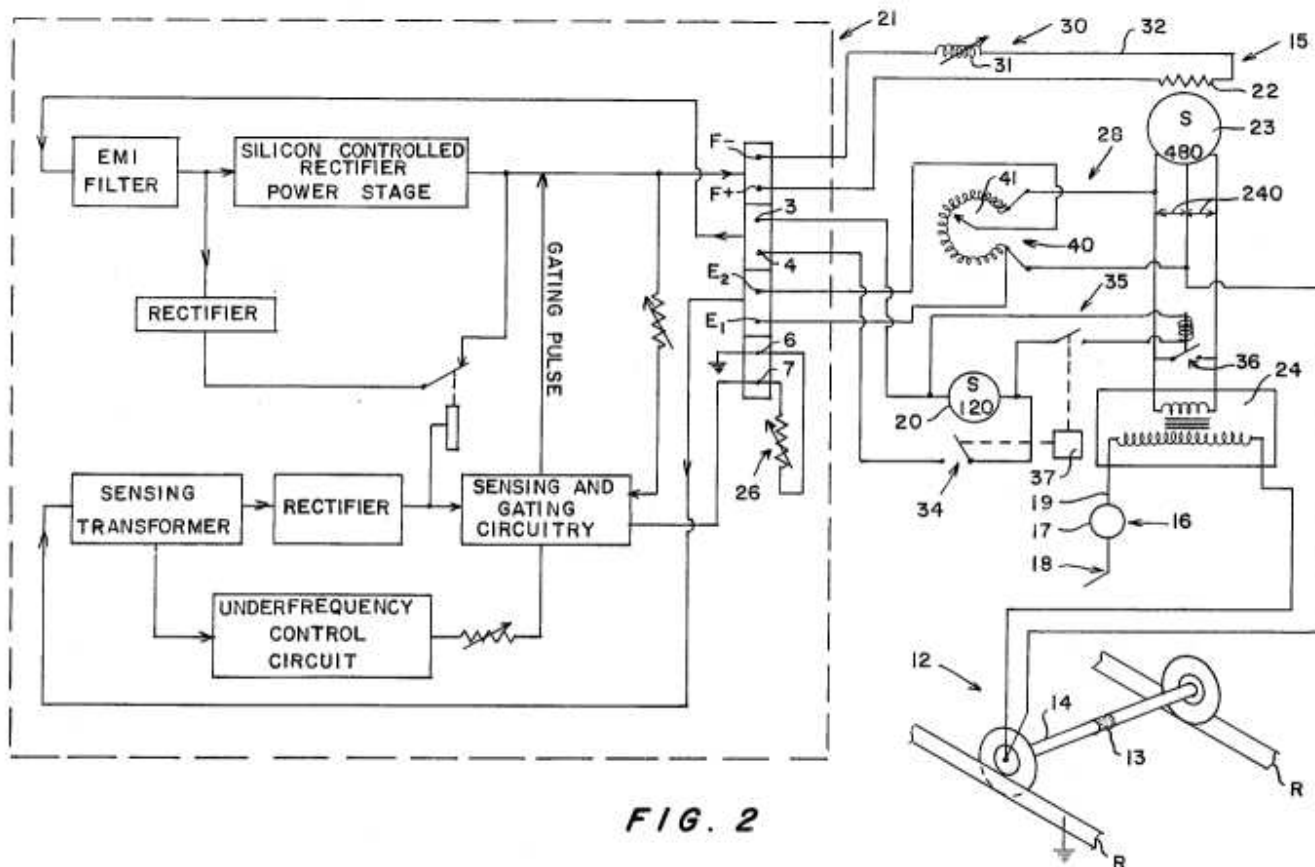
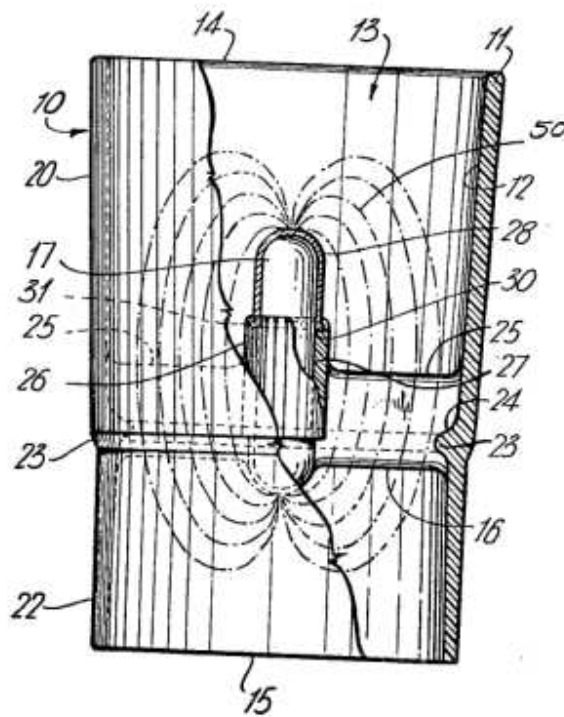

FIG. 2

**Abstract** ~ A machine and method for destroying plant growth. A specialty application is provided for plant growth around and between railroad tracks, and a general description is provided for preventing damage to the high voltage source of electricity used for the plant destruction, and for minimizing the number of fires started in dry material accessory to plant destruction. A vehicle with a high voltage electricity source is mounted on railroad tracks, with wheels of each wheel set for the vehicle being electrically isolated, and the high voltage source being grounded through one of the wheels. Special plant contacting devices comprising rounded end generally cylindrical contacting members are provided. The current output of the high voltage source is limited to prevent damage to the high voltage source, and the no-load voltage of the high voltage source is held to generally the same level as the full-load current limited voltage to minimize the number of fires started by the plant contactors.

**USP # 4,188,751  
Magnetic Seed Treating Device**

**Minoru Saruwatari  
February 19, 1980**



**Abstract** ~ A device for magnetically treating seeds prior to planting so as to increase the yield of plants grown from the seeds. The device includes a tubular member provided with an internal support for securing a permanent magnet therein so that as seeds are poured through the tubular member, they are magnetically treated. The magnet, which has opposite poles disposed at opposite ends thereof, is oriented with its longitudinal axis extending in the direction of the passage, the passage adjacent the magnet being of substantially annular shape in cross-section whereby a uniform cylindrical shaped magnetic field occupies the annular passage through which the grain must pass. The tubular member has a converging portion in the direction of seed travel so as to provide an area of maximum constriction adjacent the magnet which results in the seeds being funneled radially inward towards the more concentrated magnetic field closest to the magnet. The converging or constricted portion may be shaped to provide the flow of seeds along streamlines so that the rate of flow is enhanced.

**USP # 4,198,781**

**Plant Destruction Utilizing Electrically Conductive Liquid**

**Willis Dykes**  
**April 22, 1980**

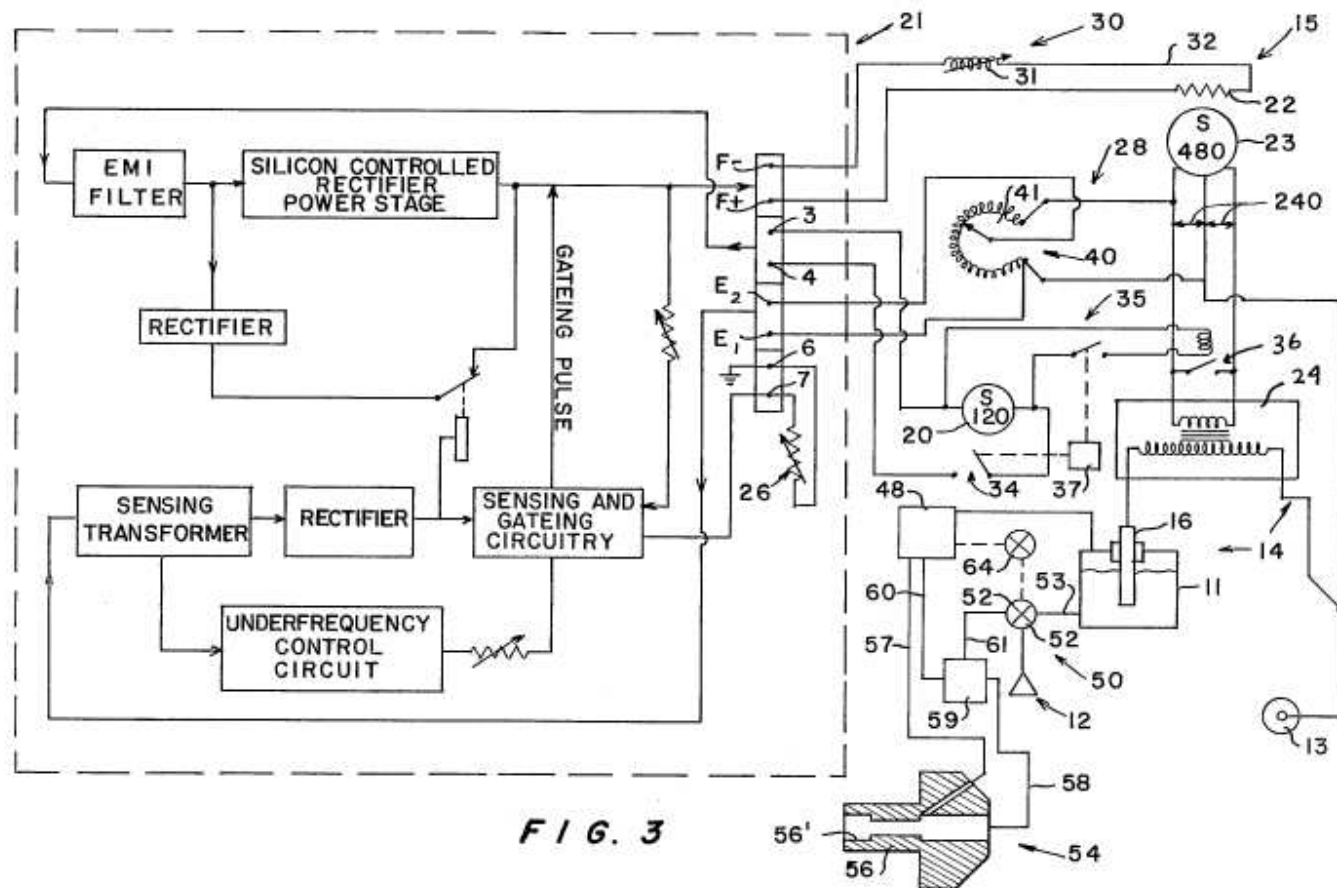

**Abstract** ~ A machine is provided for destroying plants with electricity comprising a tank adapted to hold electrically conductive liquid, an electrode for placing the electrically conductive liquid in the tank at high electrical potential, including a high voltage source of electricity; nozzles for spraying the electrically conductive liquid on plants to be destroyed; and a structure for grounding the high voltage source. Air pressure provided over the liquid in the tank provides the motive force for spraying, and pneumatically operated valves in line with the nozzles are provided for selectively supplying liquid to the nozzles. In this way, there are no moving parts which are electrically charged. Condition-responsive structures, responsive to plant position, are provided for controlling operation of the pneumatic valves, such as air limit proximity switches. The current output of the high voltage source is limited so that damage to the source is prevented, and the no-load voltage of the high voltage source also is preferably controlled.

**USP # 4,240,365  
Magnetic Seed Planter**

**Raymond D. Amburn  
December 23, 1980**

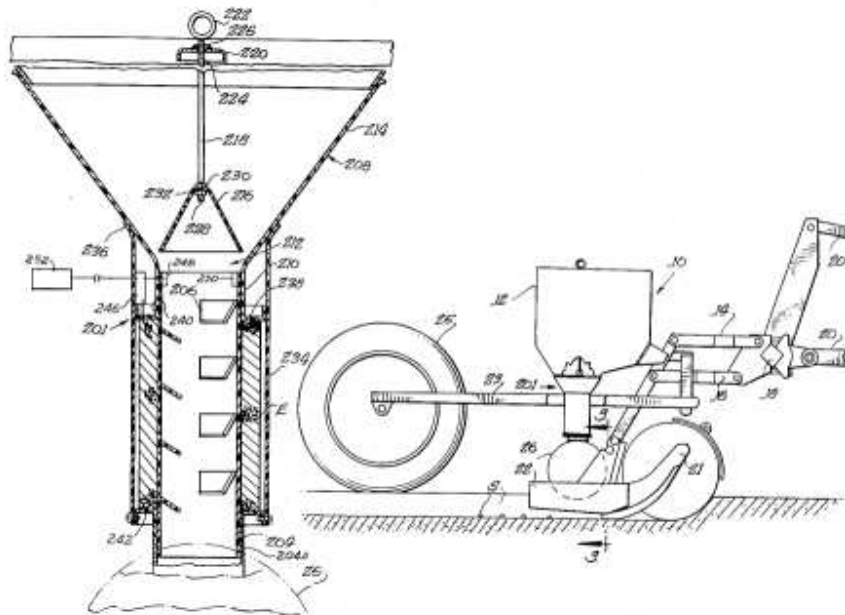

**Abstract** ~ Planting apparatus including a supporting frame adapted to be connected to a tractor or similar vehicle; a seed hopper mounted on the supporting frame for containing a supply of seeds, and seed metering mechanism spaced beneath the discharge outlet of the seed hopper for controlling the movement of the seeds discharged from the hopper on the ground. A magnetic seed treating device is disposed in the path of seeds discharged from the hopper for causing the seeds to pass through a magnetic field to magnetically treat the seeds as the seeds are planted.

## USP # 4,291,125

### Method for Electronic Control of Infections Using Silver Ions

Wilson Greatbatch  
September 22, 1981

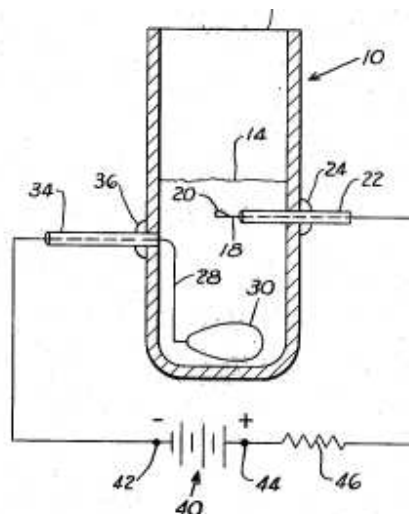

**Abstract** ~ A method and apparatus for killing plant and animal bacteria and plant viroids by electrically generated silver ions. The silver ions serve as germicidal agents in infection control and are generated by very slow electrical anodic corrosion of a silver wire located closely adjacent the

infection site. In particular, a silver anode and a cathode of non-corroding metal are located in an electrolytic nutrient medium with the silver anode being within five millimeters of the infection site, and a direct voltage is applied to the anode and cathode in a manner passing a positive current in the microampere range into the silver anode causing it to corrode slightly and give off silver ions which produce a germicidal environment about the infection site.

## USP # 4,302,670 Electrogenic Seed Treater

**Andrew Zaderej / Claude E. Corson**  
November 24, 1981

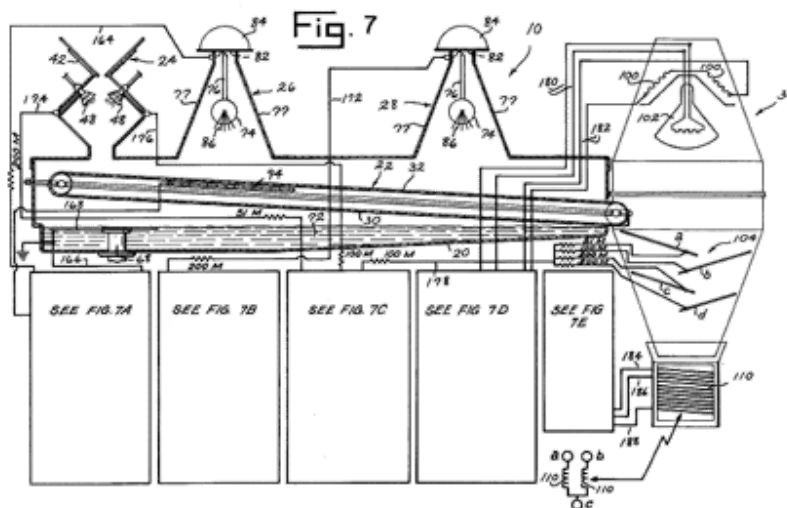

**Abstract** ~ Method and apparatus for treating seeds, such as corn, soy beans and rice, in which the seeds are first coated with a mixture of water and enzyme and then subjected to a series of electrical potentials that causes water, ion particles, and nitrogen components to be impregnated within the seed for the purpose of improving the embryonic and growth potential of the seeds.

## USP # 4,338,743 Safety System for Weed Destroying Apparatus...

**Thomas P. Gilmore**  
July 13, 1982



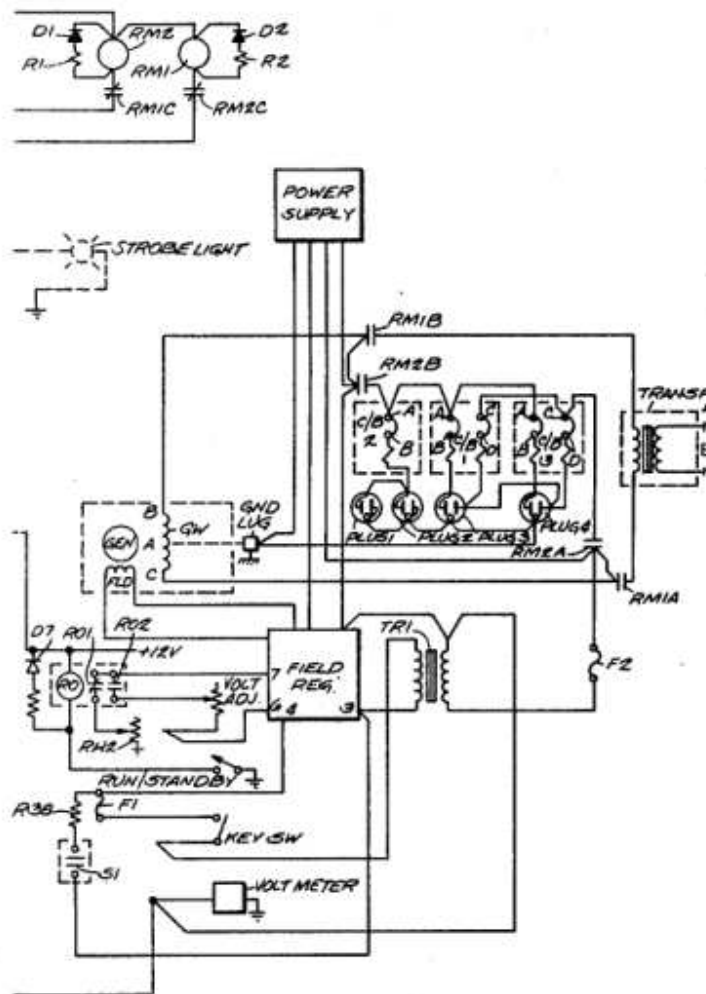

**Abstract** ~ Weed destroying apparatus carried on a vehicle has a generator; a step-up transformer having its secondary winding coupled to electrodes for contacting and killing weeds; a programmable semiconductor logic array; a first contactor coupled to an output of the logic array for connecting the generator to the transformer primary winding in the weed killing mode; a second contactor coupled to an output of the logic array for connecting the generator to electrical outlets for supplying electrical power to auxiliary farm equipment in a standby mode; a run/standby switch for providing binary signals to the logic array indicative as to whether the apparatus is to operate in the weed killing mode or the standby mode; a plurality of safety systems each of which has redundant interlock means for preventing an unsafe condition in which high voltage would be a hazard in the weed killing mode and sensing means for providing binary signals to the logic array indicative of whether each interlock means is in the safe condition or an unsafe condition; and a generator frequency interlock for detecting generator frequency in the standby mode and for applying binary signals to the logic array indicative of whether generator frequency is within a predetermined range.

USP # 4,338,744

## Safety System for Weed Destroying Apparatu

Thomas P. Gilmore  
July 13, 1982

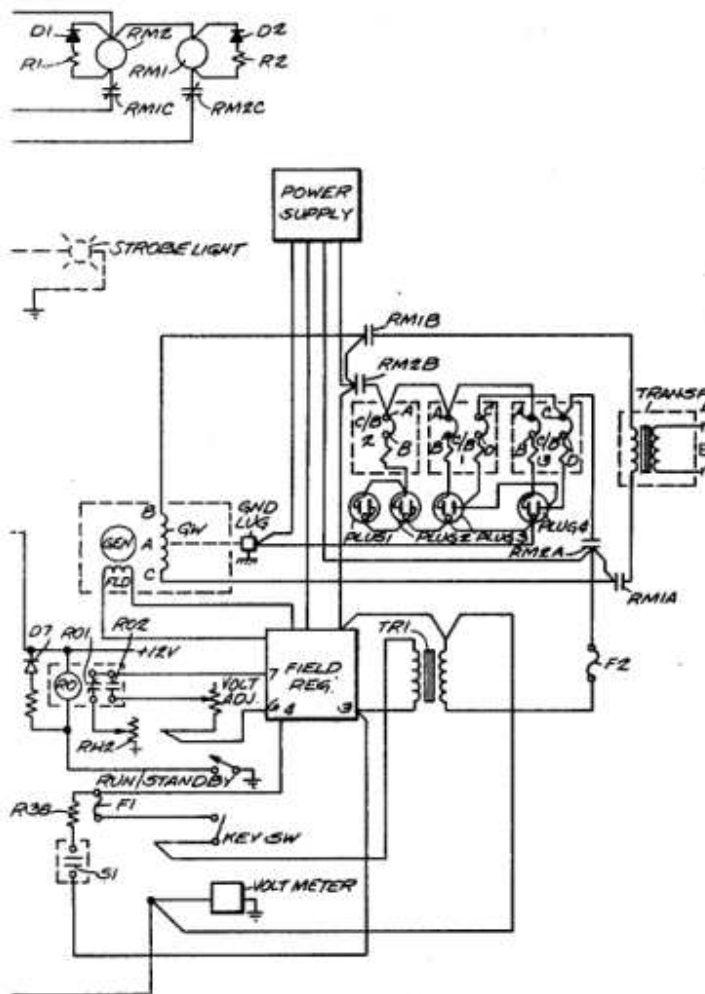

**Abstract** ~ A weed destroying system carried on a vehicle and having electrodes for contacting weeds and a high voltage generator and a step-up transformer for supplying high voltage to the electrodes is provided with a tamper-proof safety system having redundant safety interlocks to effectively ground the vehicle and redundant safety interlocks to prevent energization of the generator until the vehicle is traveling at a predetermined speed and which de-energizes the generator if any one safety interlock is bypassed or fails in an unsafe condition, thereby requiring plural simultaneous failures to create a condition that is hazardous to the operator or to a bystander. The safety system also provides immediately-visible warning of the electrical hazard created by the apparatus and provides visual and aural indications to the operator when a safety interlock has been bypassed or is jammed closed.

**USP # 4,428,150**

**Electrode Arrangement for Electric Weed Killing Apparatus**

**Allois F. Geiersbach**

**January 31, 1984**

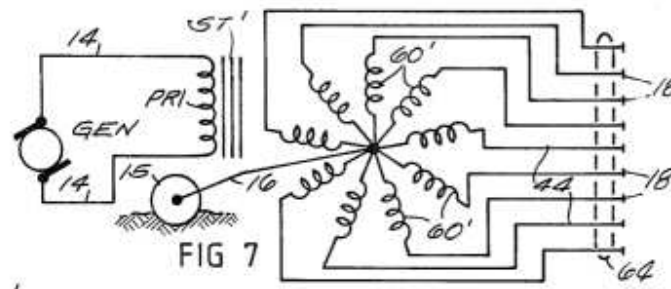
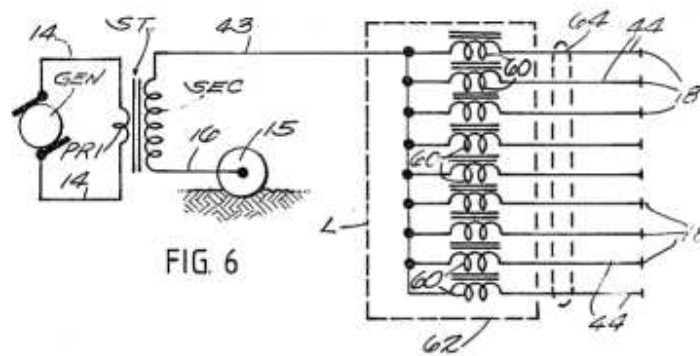

**Abstract** ~ Apparatus for destroying weeds in and around crop rows has a high voltage source of electricity mounted on a vehicle; a coulter wheel for connecting the high voltage source to the ground; a plurality of weed contacting electrodes carried on the vehicle and insulated therefrom; and a plurality of isolating electrical reactance inductors each of which connects a weed contacting electrode to the high voltage source and limits the magnitude of current flowing through the high voltage source when the electrode contacts a weed to thereby minimize the voltage drop across the high voltage source and maintain substantially constant voltage on the remaining electrodes.

## USP # 4,633,611 Process and Apparatus for Disinfecting Seeds

Siegfried Schiller, et al.  
January 6, 1987

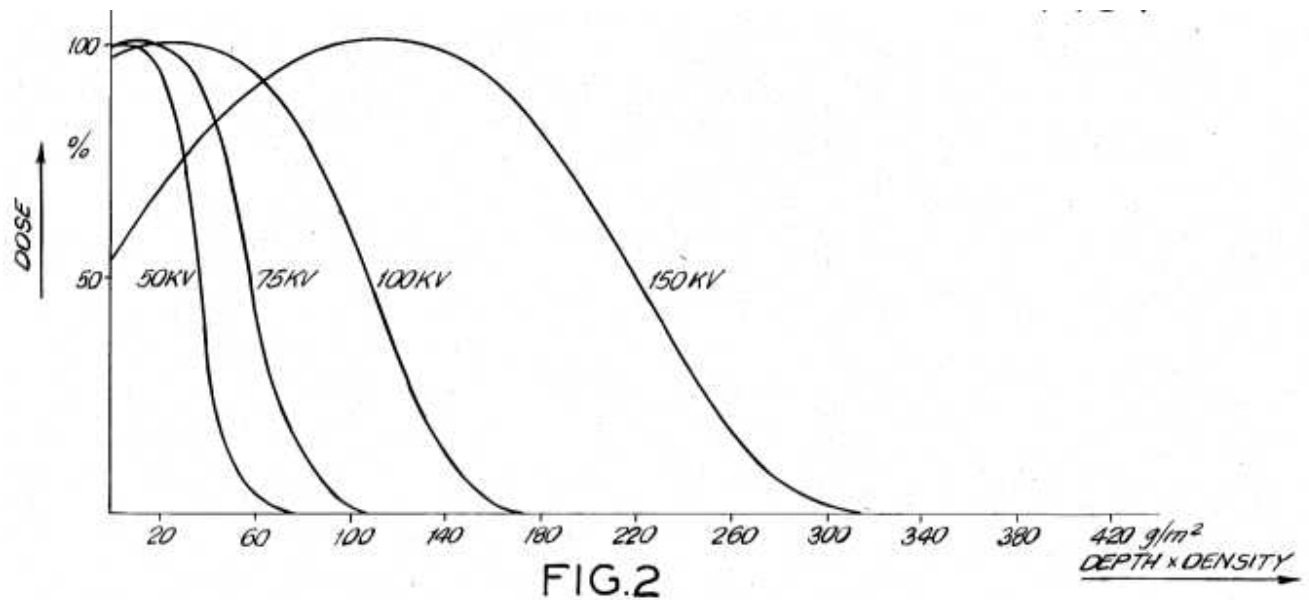

FIG. 2

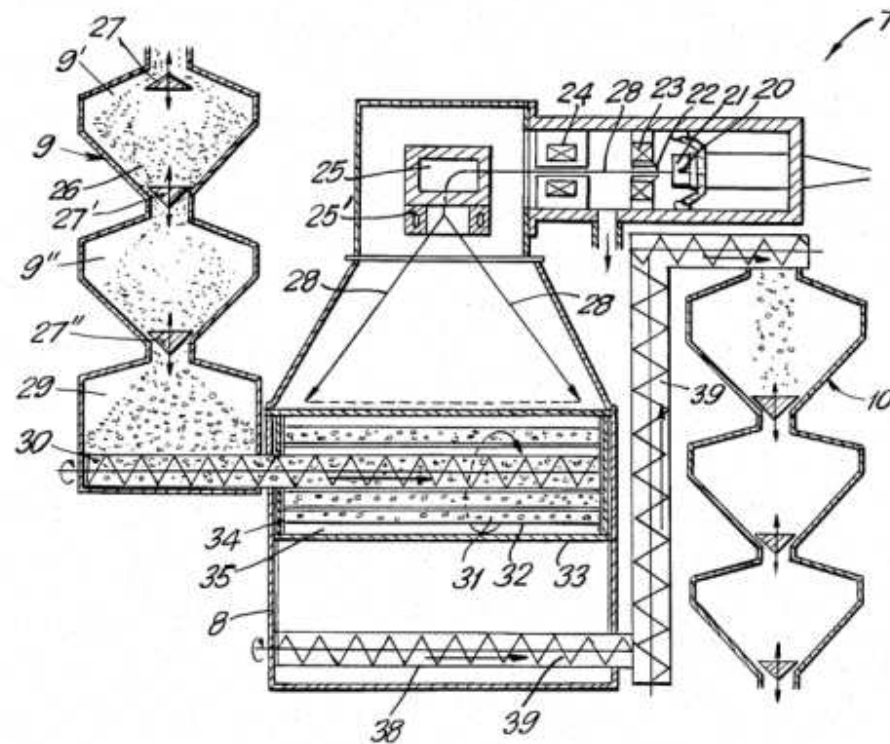

FIG. 5

**Abstract** ~ An apparatus and process for the disinfection of seeds, preferably those of grains, to prevent pathogenic organisms from being planted with the seeds, and to provide reliable disinfection without using toxic agents. The seed is irradiated by low-energy electrons with energy and dosage controlled so that the surface and regions close to the surface are exposed to the radiation with fungicidal effect. A beam of the low-energy electrons is provided by an electron gun aimed at a region within a seed-receiving chamber at which the seeds to be irradiated are caused to intercept the radiation repeatedly and on all sides. The chamber may be at atmospheric pressure or be evacuated, the latter condition requiring vacuum locks at seed inlet and outlet ports of the chamber.

**USP # 4,680,889**  
**Process for Treating Plants**

**Dan R. Carlson**

**July 21, 1987**

**Abstract** ~ The present invention is a process for stimulating or inhibiting plant growth and includes the steps of applying a plant growth stimulant or inhibitor and subjecting the plant to high frequency sound waves.

---

**USP # 4,758,318**  
**Method for Improvement of Soil**

**Tadayuki Yoshida**

**July 19, 1988**

FIG. 1

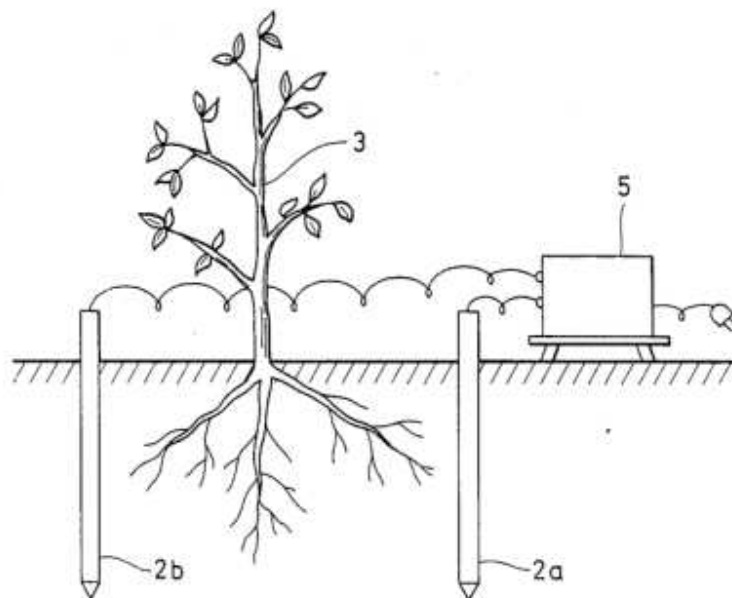

FIG. 2

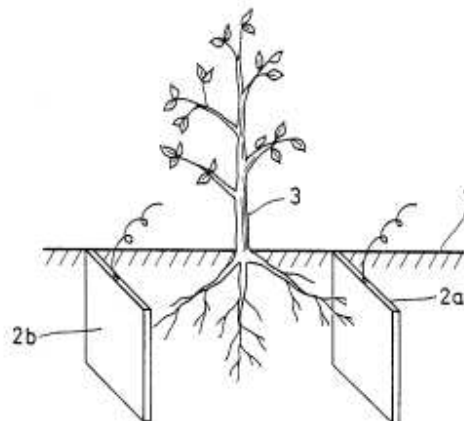
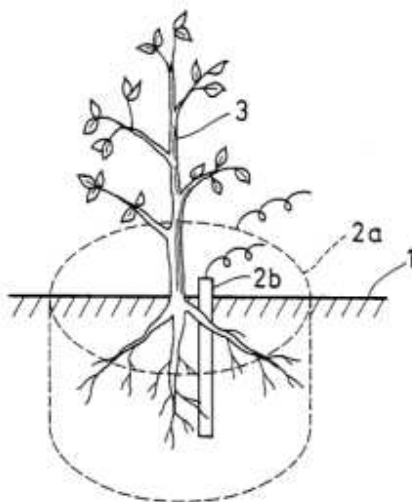

FIG. 3



**Abstract** ~ The molds infesting a given soil are extirpated by the flow of a pulsating direct current of not less than 50 mA to prevent a farm product from diseases causable by the aforementioned molds.

USP # 4,785,575

### Horticultural Device for Raising Garden Plants Utilizing Magnetism

Kazuhiro Shioi  
November 22, 1988

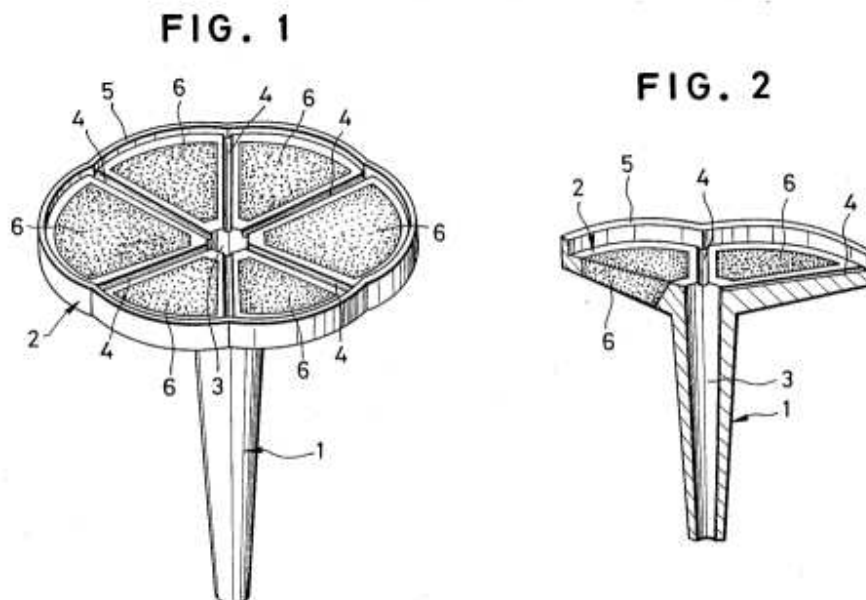

**Abstract** ~ A horticultural device utilizing magnetism for raising plants includes a plate-shaped section in which a fertilizer is imbedded, and a rod-shaped section extending from the bottom side of the plate-shaped section and having a fluid flow passageway, at least a portion of the device having a magnetic property. The rod-shaped section is thrust into soil surrounding a plant until the plant-shaped section contacts the soil surface. The fertilizer carried in the plate-shaped section is gradually dissolved and converted into a magnetized fertilizer solution by watering, the fertilizer solution dispersing itself into the soil through the liquid flow passageway of the rod-shaped section.

### USP # 4,891,317

#### Magnetic Alternation of Cellulose During Its Biosynthesis

Malcolm Brown, Jr., et al.

January 2, 1990

**Abstract** ~ A method of producing cellulose of amorphous character by subjecting cellulose-producing organisms to a magnetic field substantially greater than 0.5 gauss and preferably at least about 500 gauss. The cellulose produced in the presence of a magnetic field is of an amorphous nature with increased water absorptivity and decreased crystallinity.

### USP # 4,915,915

#### Water-Powered Piezoelectric Unit for Producing Nitrogen Fertilizer

Richard W. Treharne

April 10, 1990

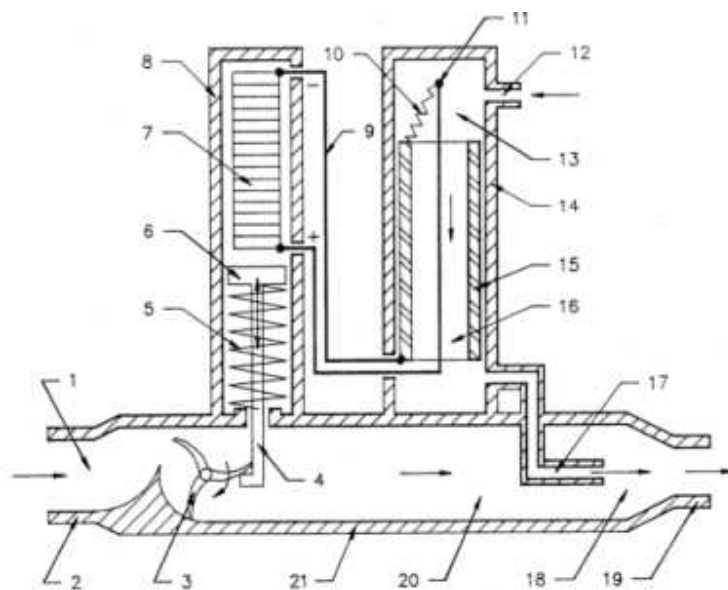

Figure 1

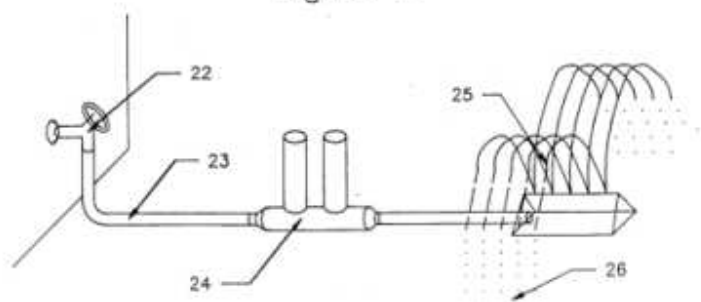

Figure 2

**Abstract** ~ A system for producing nitrogen fertilizer using an electric arc process is described in which the electric arc necessary for the process is generated by piezoelectric elements actuated by a hammer mechanism powered by water pressure such as from a garden hose. The nitrogen oxides produced by the arc discharge are drawn into the water to serve as a source of nitrogen fertilizer. The net result of the invention is that the operator can provide nitrogen fertilizer as he supplies water to the same area. The only inputs to this system are air and a source of water under pressure.

## USP # 5,060,414

### Phytotoxicity of a Combined RF and Microwave Electromagnetic Field

J. Robert Wayland  
October 29, 1991



Fig. 10.

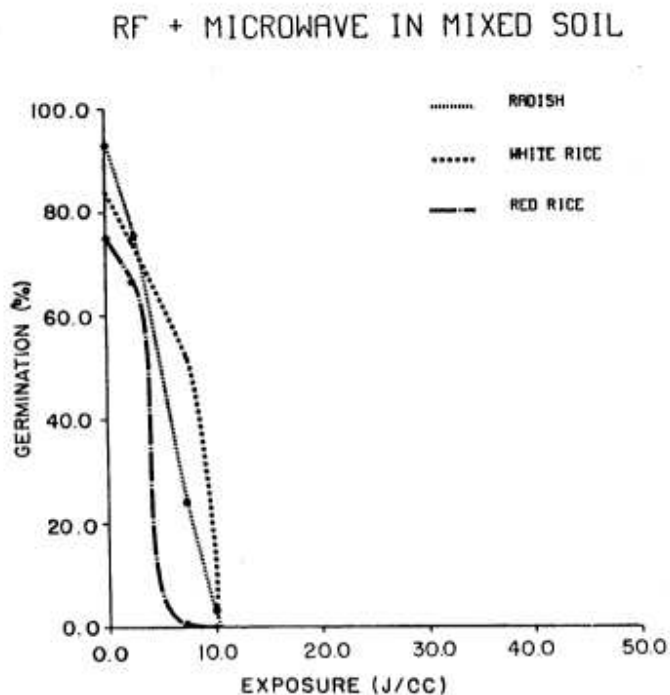

**Abstract** ~ A method and device for vegetation control. More particularly a technique of a plurality of steps in the application of electromagnetic fields of two or more selected but different frequencies, at least one in the ratio frequency range being first applied followed by application of others in the microwave region, to the area in which vegetation is to be controlled.

**USP # 5,077,934**  
**Method and Apparatus for Controlling Plant Growth**

**Abraham R. Liboff, et al.**  
**January 7, 1992**

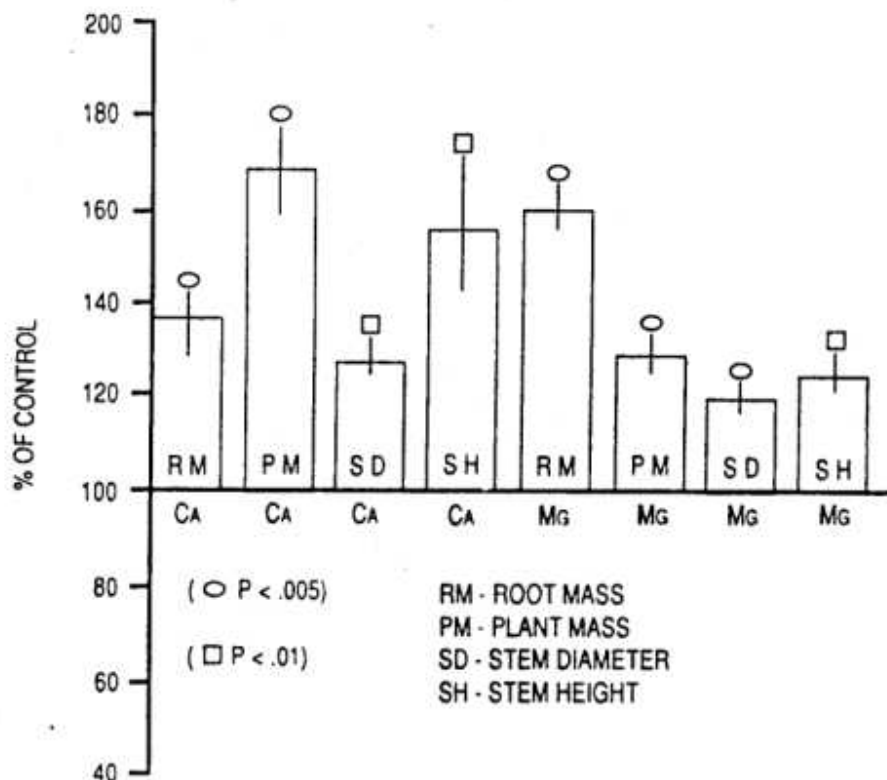

**Abstract** ~ A method and apparatus for controlling plant growth is provided. The apparatus includes a magnetic field generator for producing a controlled, fluctuating, directionally oriented magnetic field parallel to a predetermined axis projecting through viable plant material. In one aspect, a magnetic field detector measures the magnetic flux density along the predetermined axis. The applied magnetic field may comprise a full-wave rectified signal oscillated at predetermined frequencies to maintain a preselected ratio of frequency to the non-zero average value of the flux density, where the ratio is effective in altering the natural growth characteristics of the target plant material, such as accelerating growth rate. This ratio is maintained by adjusting the frequency of the fluctuating magnetic field and/or by adjusting the intensity of the applied magnetic field after nulling out or measuring and accounting for the local magnetic field in that region containing the target plant material.

**USP # 5,097,625**

## **Seeding and Seedling-Growing Sheet and Seeding and Seedling-Growing Method**

**Tadao Kaneko**  
**March 24, 1992**

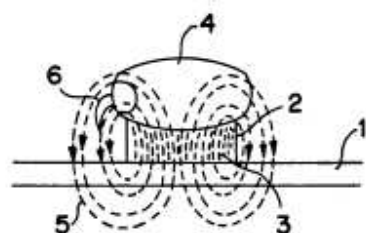

GROWING  
LENGTH OF  
MAIN ROOT  
(mm/15h)

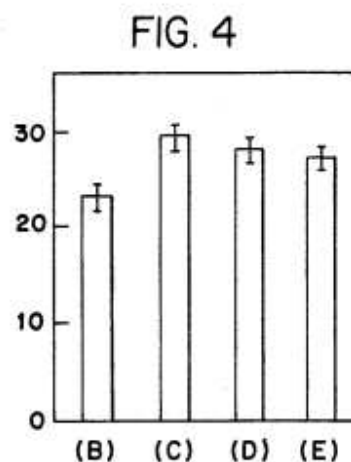

**Abstract** ~ The present invention is to provide a seeding and seedling growing sheet and a seeding and seedling-growing method comprising using the sheet, which are to be used for seeding and growing seedling of grain, vegetable, flower and the like, and which are suitable for efficiently seeding at a desirable position and a desirable density with a higher positional precision and for promoting the growth at germination, by employing the seeding and seedling-growing adhesive sheet comprising a sheet support body composed of water-soluble or water-dispersible paper or water-soluble polymer film, an adhesive agent containing a powdery ferromagnetic substance being coated in spots or in stripes on the support body, and by applying the seeding and seedling-growing method comprising using the adhesive sheet.

USP # 5,117,579

## Method and Apparatus for Applying Fixed Nitrogen to Plants

Willis A. Tellefson

June 2, 1992

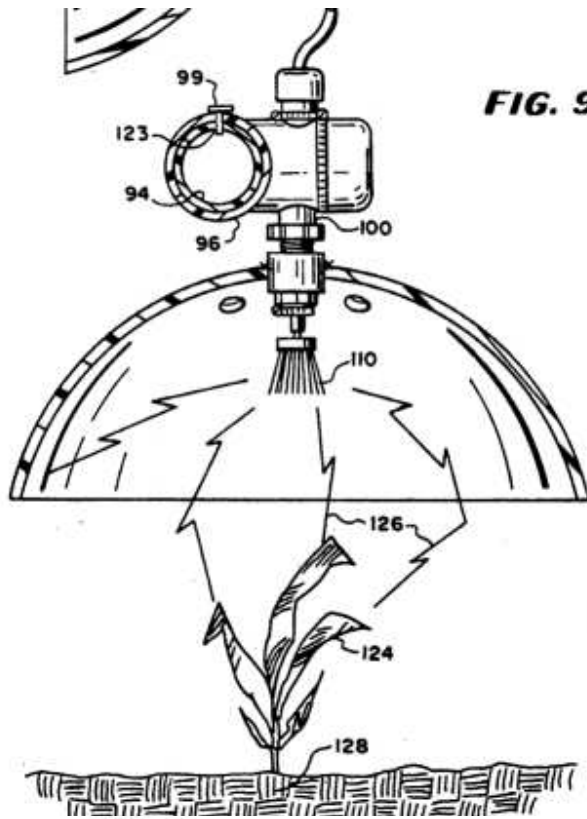
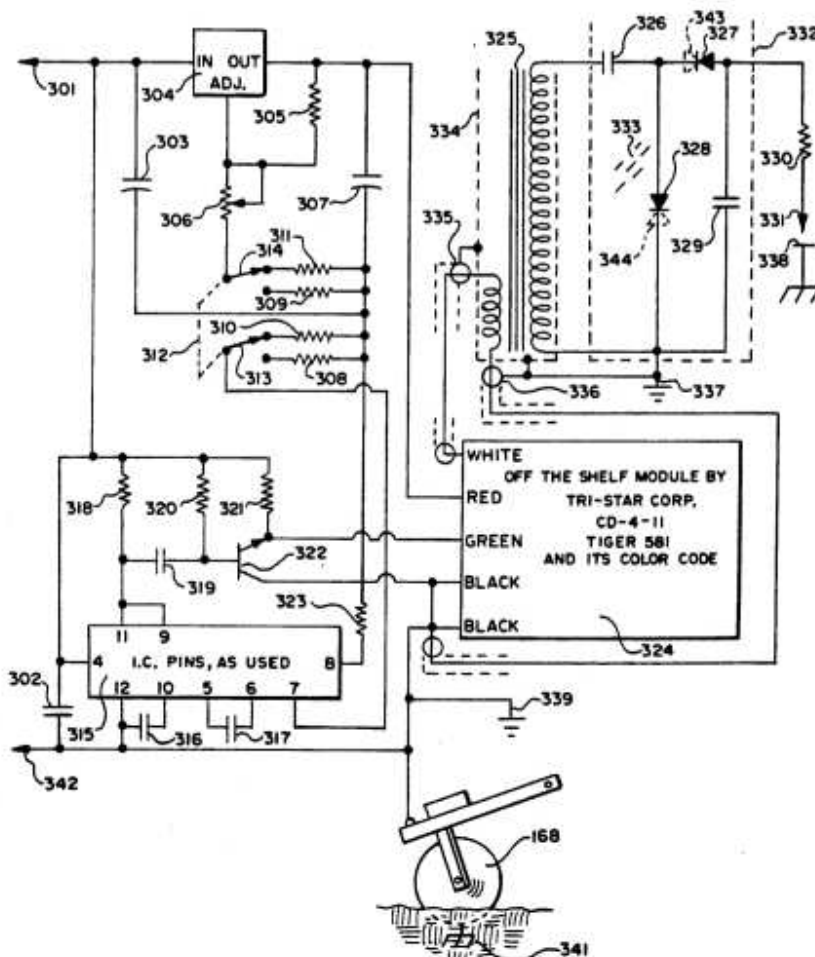

FIG. 9

FIG. 16



**Abstract** ~ An electrical ion emitting farming implement to be moved over a field of crop planted in earth for above ground atmospheric treatment of growing plants comprising a frame. A series of bell-

shaped members are mounted at spaced intervals on a boom across its transversely extended length and with the bell-shaped members opening in a downward direction toward underlying plants in a field of crops. A wire brush-like ion emitter is centrally mounted in each of the bell-shaped members. An electrical circuit ion generating mechanism operatively connected to the wire brush-like ion emitters for emitting electrical ions in the 30 to 50 KV range through the wire brush-like ion emitters. A power source is provided for energizing the electrical circuit means. A control is provided for activating the electrical circuit means for causing ion emission through the wire brush-like ion emitters upon placement of the bell-shaped members in spaced overhead position relative to the plants being treated. The electrical circuit ion generating means includes a pulsed high output ion generator. The generator has at least of pair of selectable frequencies operable in a range of 90 HZ through 400 HZ. is positioned forwardly of the emitters to be dragged in the earth to complete the circuit.

## USP # 5,141,059

### Method and Apparatus for Controlling Agricultural Pests in Soil

Leland C. Marsh

August 25, 1992

**Abstract** ~ A method and apparatus for controlling agricultural pests in soil by the use of microwave energy. By using an agricultural-type implement for the controlled application of microwave energy to the topsoil prior to the planting of crops, germination of weed and other seeds is inhibited and insects are destroyed. Use of microwave energy has no residual effects, thereby practically eliminating any adverse effects on the environment.

## USP # 5,271,470

### Plow Apparatus and Method Using Acoustics

Billy R. King / Walter F.Rausch

December 21, 1993

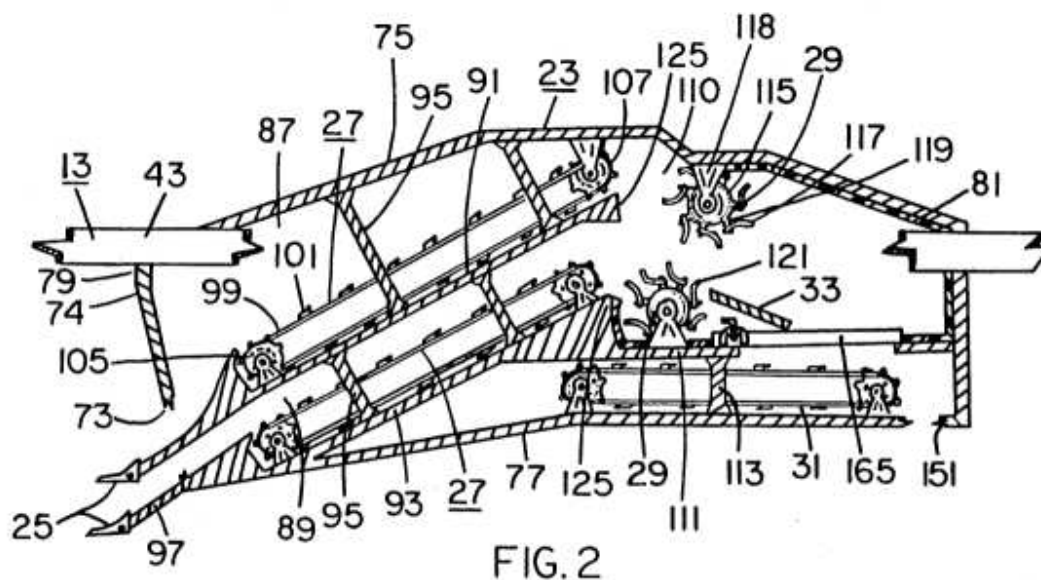

FIG. 2

**Abstract** ~ The plow apparatus has plow blades to break up the soil in the plowed field. The broken up soil is scooped up with scooper blades by the forward motion of the plow apparatus and then conveyed to rotating tillers. The tillers break up the soil into smaller clumps. The tilled soil is then exposed to

acoustical energy provided by acoustical transducers. The acoustical energy is of a sufficiently high intensity so as to kill or destroy weed seeds and insect larvae in the soil. The soil is then returned to the ground.

## USP # 5,464,456 Electronic Stimulation of Plants

**M. Glen Kertz**  
**November 7, 1995**

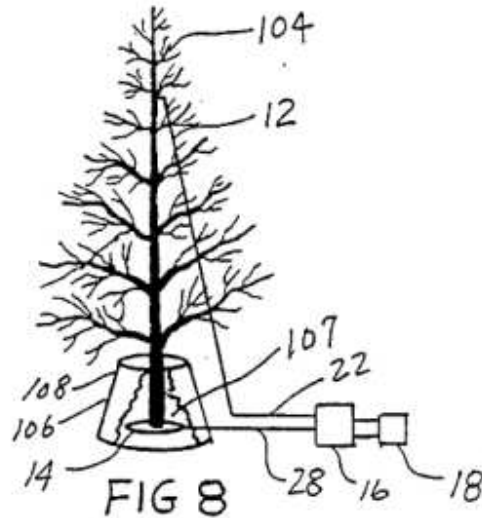

**Abstract** ~ The invention relates to the electronic stimulation of plant development. More particularly, it relates to the stimulation of plant development through electrifying the environment around a plant or part of a plant with an electrical field, preferably a pulsed field. The present invention also relates to an electronic method of stimulating the active membrane transport systems of growing plants and harvested plant products in order to promote growth and extend the shelf life of harvested material. The invention is of particular interest as it relates to shipment and marketing of cut flowers, greens and trees and more particularly to methods and apparatus for handling, shipping, and marketing of cut flowers.

## USP # 5,600,918 Apparatus for Killing Weeds

**Edwin R. Carr**  
**February 11, 1997**

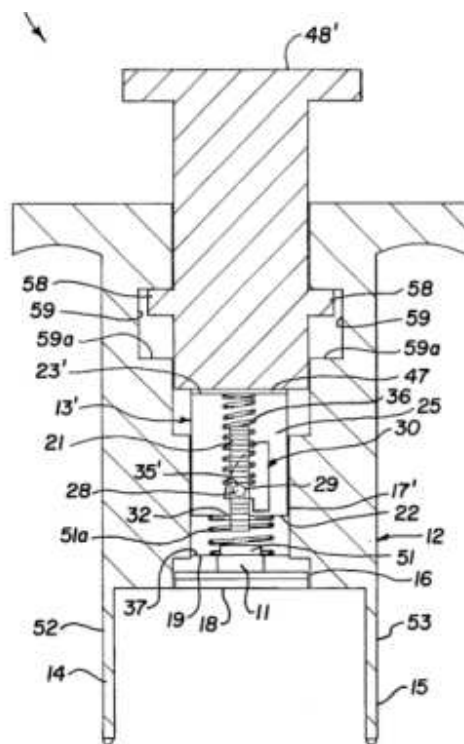

**Abstract** ~ Apparatus which comprises a housing having a compartment and a shaft, a piezoelectric crystal captured in the compartment of the housing and an actuator assembly slideably disposed in said shaft for selectively applying a compressive force to the crystal is used to kill weeds by impressing a voltage across the roots of the weed. An electrically conductive path is formed between one end of the crystal and ground. A second electrically conductive path is formed between the other end of the crystal and a probe adapted for insertion into the roots of a weed. When a compressive force is applied to the crystal, the voltage generated is passed through the root to ground to kill the root, thereby destroying the weed.

### USP # 5,740,627

## Method and Apparatus for Enhancing Growth Characteristics of Seeds Using Ion-Electron Avalanches

**William C. Levensgood**

**April 21, 1998**

**Abstract** ~ A method and apparatus for treating seeds with self-organized avalanches of electrons between electrodes (11, 12) as a cathode and an anode with seeds (13) between the anode and cathode or on the anode. Apparatus circuit (200) in a box (20) provides simultaneous DC and AC between the electrodes which creates the avalanche of electrons which project into the seeds. The seeds must be stored before planting. The seeds so treated have enhanced growth characteristics.

### USP # 5,806,294

## Weed Electrifier

**Louis C. Strieber**

**September 15, 1998**

**Abstract** ~ A portable, hand held tool for trimming and electrifying vegetation. The portable, hand swingable, weed trimmer passes electricity through its cutting or trimming element so as to pass electricity into the weeds to kill the roots of the weeds. The tool includes a power unit for rotation of a

cutter drive. A pancake generator generates electricity via rotation of the cutter drive. Brushes between the pancake generator and the cutter blade conduct current to the cutter blade, which in turn permits the current to pass into the vegetation as the cutter blade trims the vegetation.

## USP # 5,819,467 Method of Stimulating Plant Growth

**Jonathan M. Zucker**  
October 13, 1998



**Abstract** ~ A conductive helical coil is spaced around the stem of a growing plant, and alternating current is passed through the coil to induce an electromotive force in the stem and stimulate growth.

## USP # 5,868,919 Method and Apparatus for Dissociating Materials

**Peter D. Babington, et al.**  
February 9, 1999

**Abstract** ~ An apparatus and method of use for dissociating materials includes a power supply, high energy capacitor, high energy trigger device and an probe and reactor arrangement for treating both solid and medium/media materials. A near instantaneous discharge of the electrical charge stored in the capacitor via the probe can be used to dissociate the material, either medium/media or solid, for a desired result. Hazardous materials can be treated to be rendered non-hazardous, rocks or other solid material can be treated for reduction in size, plant seeds can be treated to enhance plant growth surfaces of granular material can be scored or thermally polished and milk, juices and blood could be treated for sterilization.

## USP # 6,023,880 Method and Apparatus for Enhancing Growth Characteristics of Seeds Using Ion-Electron Avalanches

**William C. Levensgood / John A. Burke**  
February 15, 2000



**Abstract** ~ A method and apparatus for treating seeds with self-organized avalanches of electrons between electrodes (11, 12) as a cathode and an anode with seeds (13) between the anode and cathode or on the anode. Apparatus circuit (200) in a box (20) provides simultaneous DC and AC between the electrodes which creates the avalanche of electrons which project into the seeds. The seeds must be stored before planting. The seeds so treated have enhanced growth characteristics.

## USP # 6,055,768 Apparatus for Electrically Charging Fluids

**Joe E. Burkett**

**May 2, 2000**

**Abstract** ~ The present invention relates to a method and apparatus to energize a fluid. In one embodiment, the apparatus comprises a housing defining a bore therethrough within which is disposed an antenna so as to define an annulus between the housing and the antenna, the antenna being electrically coupled to both the housing and an electrical power source so as to create an electrical field through which water or other fluids may be passed [to feed plants].

## USP # 6,192,622 Mobile Device to Eradicate Red Palm Weevils and Trees Stem Borers

**Yosri Moh'd Taher Haj-Yousef**

**February 27, 2001**

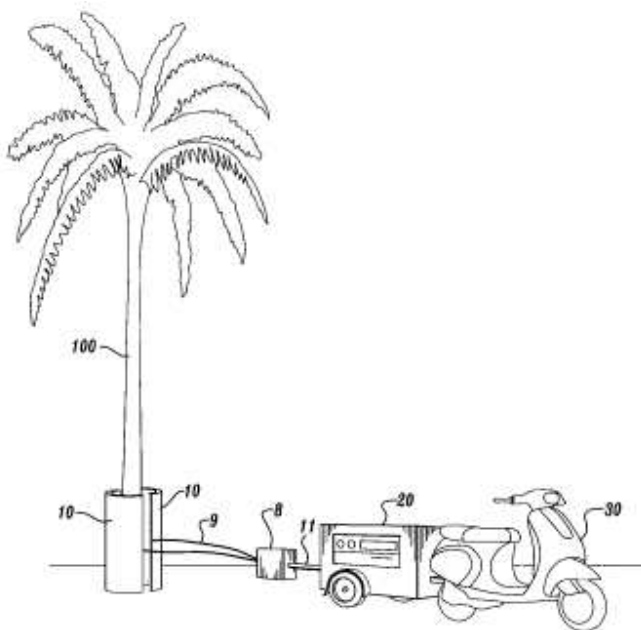

**Abstract** ~ A high frequency power source (4) and (5) supplies electromagnetic waves (10-100 MHz) that are supplied to a single or a pair of plates that surround a trunk of the infested tree. The electromagnetic waves are used to kill red palm weevils and trees stem borers within the trunk of the tree. The plates are cylindrical, half cylindrical or flat, with insulated metal sheets that surround the trunk and upper roots of the infested tree.

## USP # 6,237,278 Method and Device for Weed Control

**Bertil Persson, et al.**

**May 29, 2001**

**Abstract** ~ Weed seeds are controlled by high voltage pulses with short duration which electropermeabilize the cell membranes of weed seeds in the ground. The device is selective and damages only germinating weed seeds and plants early in their life cycle. The required amount of energy is small; with rectangular pulses the optimal field strength is between 100-300 kV/m with a duration of (10-100 microseconds). A transformer placed on a sowing machine transforms electrical energy to high voltage pulses. The energy may be taken from the pulling tractor via a transmission or from an integrated power source. The high voltage pulses are applied to electrically conducting via applicators to two or more fixedly spaced plates to the soil around newly sown seeds.

## USP # 6,539,664

### Method and Devices for Treatment of a Biological Material with a Magnetic Field

**Alexander Katsen, et al.**

**April 1, 2003**

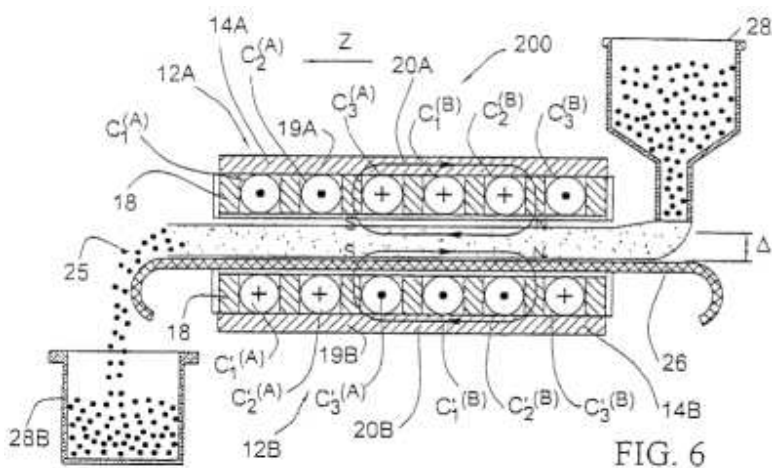

**Abstract** ~ A device for the manipulation of a biological material [seeds] by a magnetic field is presented. The device comprises a magnetic field source coupled to a current source. The current source is of a kind supplying an electric current of at least two electrical degree shifted phases. The magnetic field source comprises a two-part inductor, each inductor part producing a coordinate varying magnetic field (CVMF). Each inductor part is formed by at least two conductors aligned in a spaced-apart relationship, wherein each of the at least two conductors is connectable to a different phase of the current source, and has two spaced-apart parts arranged such that when the conductor is connected to the current source, the electric current flows in its two parts in opposite directions, respectively. The conductors of each inductor part are arranged such that each two locally adjacent conductor parts are associated with two different phases of the electric current source. A distance between the two conductor parts coupled to the same phase of the current source defines a half-wavelength  $\lambda/2$  of a wave of magnetic induction of the CVMF. This distance is selected in accordance with a predetermined relation between the wavelength  $\lambda$  and an effective space  $\Delta$  within the magnetic field region defined by the dimensions of the biological material and its distance from the magnetic field source.



**Your Support Maintains this Service --**

**BUY**

**The Rex Research Civilization Kit**

**... It's Your Best Bet & Investment in Sustainable Humanity on Earth ...**

**Ensure & Enhance Your Survival & Genome Transmission ...**

**Everything @ [rexresearch.com](http://rexresearch.com) on a Thumb Drive or Download !**

**[ORDER PAGE](#)**

---